

Acceval VEN-4

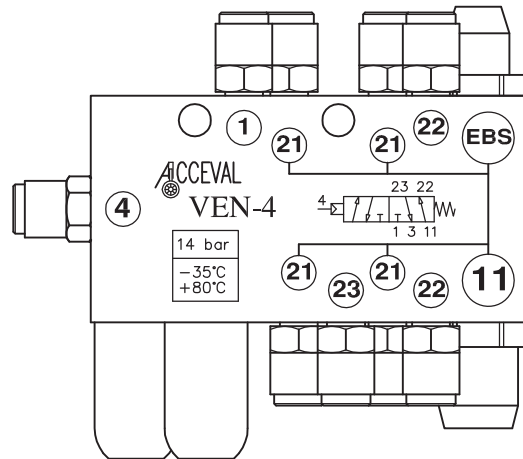

Lift Axle Control Valve
Pneumatically Commanded
From EBS System

For Suspensions with
Single Circuit

Air Suspension
Distribution Block

ACCEVAL VEN-4

AIR DISTRIBUTION BLOCK WITH
LIFT AXLE CONTROL VALVE FOR
EBS SYSTEM WITH AIR OPERATION
(SUSPENSION: SINGLE CIRCUIT)

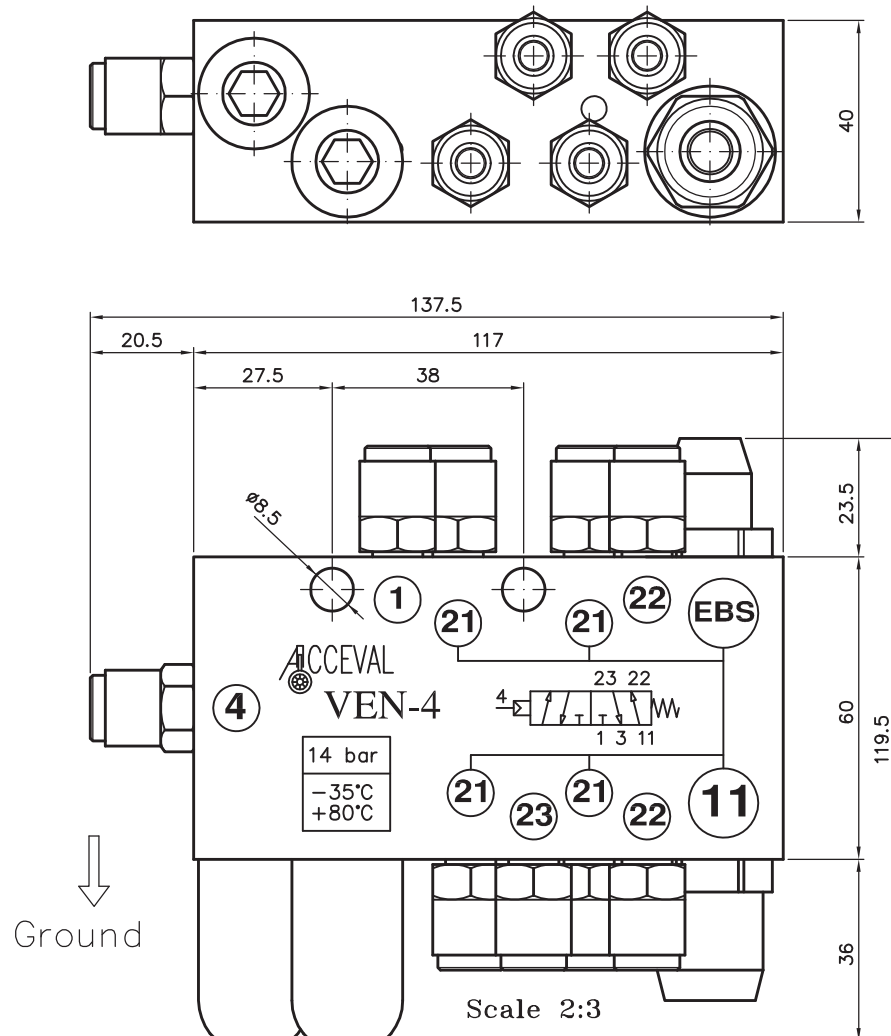

WORKING SPECIFICATIONS

- * Pneumatical scheme: see drawing.
- * Max. working pressure: 14 bar.
- * Safe static pressure: 20 bar.
- * Temp. range: from -35°C to $+80^{\circ}\text{C}$.

PNEUMATICAL CONNECTIONS

Ports n.1, n.4, n.21, n.22 and n.23

- * Automotive push-in fittings T-8mm.

Port n.11

- * Automotive push-in fittings T-12mm.

Port n.3 (Exhaust) and breathing

- * Filter + filter cover.

Installation

- * Port n.1: Air pressure inlet.
- * Port n.4: Air command from EBS.
- * Port n.11: From raise/lower valve.
- * Port n.21: To non-lift axle bellows.
- * Port n.22: To lift axle bellows.
- * Port n.23: To lifter.
- * Port "EBS": To EBS pressure sensor.

ACCEVAL VEN-4
BASICAL CONNECTIONS SCHEME
 (Suspension: Single Circuit)

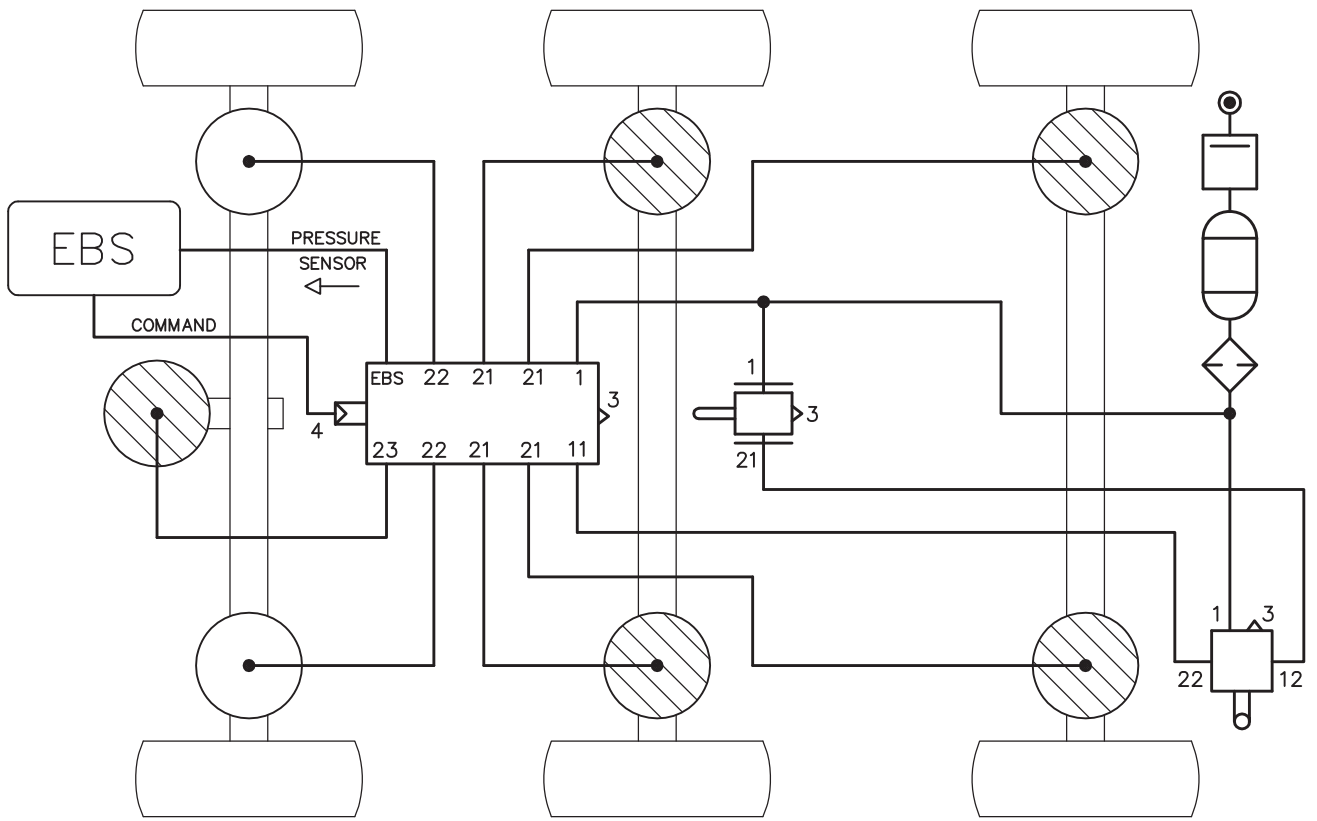

ACCEVAL VEN-4
PNEUMATICAL SCHEME
 (Suspension: Single Circuit)

