

Acceval VEB-11

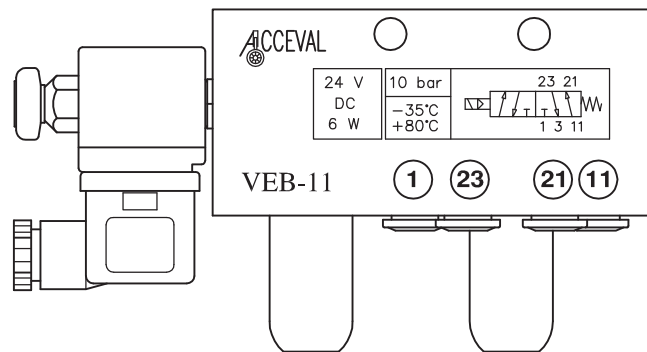

Lift Axle Control Valve
Electrically Commanded
From EBS System

For Suspensions with
Single Circuit

ACCEVAL VEB-11

LIFT AXLE CONTROL VALVE FOR EBS SYSTEM

(SUSPENSION: SINGLE CIRCUIT)

Scale 3:5

WORKING SPECIFICATIONS

- * Pneumatic Scheme: See Drawing.
- * Max. Working Pressure: 10 bar.
- * Safe Static Pressure: 15 bar.
- * Temp. Range: from -35°C to $+80^{\circ}\text{C}$.
- * Solenoid: 24VDC 6W or 12VDC 9W.
- * Electrical Duty: 100%.
- * Solenoid with Industrial Connector DIN43650 (IP65) or Bayonet Connector DIN72585-A1-2.1 (IP68).
- * Electromagnetic compatibility (EMC) according to 89/336/EEC.
- * Low voltage equipment (LVD) according to 73/23/EEC.

PNEUMATICAL CONNECTIONS

Ports n.1, n.23, n.21 and n.11

- * Insertable push-in fittings for 8mm, 10mm, 5/16", or 3/8" tubes.

Port n.3 (Exhaust) and Breathing

- * Filter + filter cover.

Exhaust port of solenoid valve

- * Rubber cup protection.

Installation

- * Port n.1: Air Pressure Inlet.
- * Port n.11: Suspension Line.
- * Port n.21: Lift Axle AirSprings.
- * Port n.23: Axle Lift.

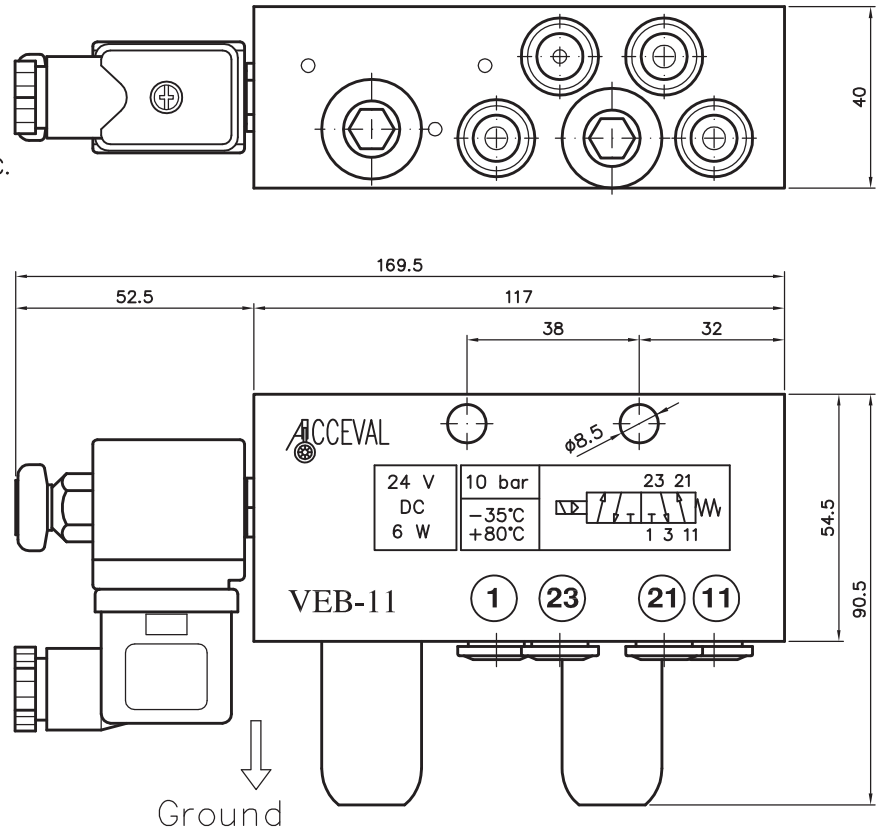

ACCEVAL VEB-11

PNEUMATICAL SCHEME

(Suspension: Single Circuit)

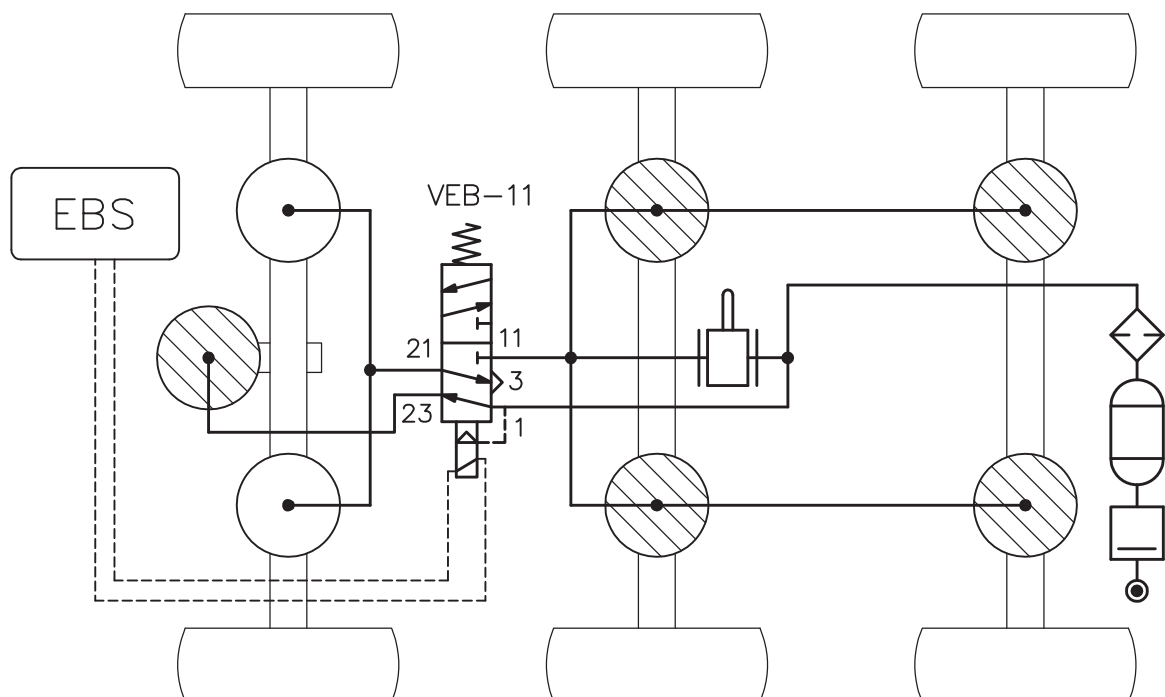

ACCEVAL VEB-11

VERSIONS AND ANCHORING ORIENTATION

VERSIONS

Valve Code	Push-in Fittings for:				Solenoid Voltage		Solenoid Connector	
	8mm tube	10mm tube	5/16" tube	3/8" tube	24 VDC	12 VDC	Industrial type	Bayonet type
VEB11-0824I	✗				✗		✗	
VEB11-1024I		✗			✗		✗	
VEB11-0824B	✗				✗			✗
VEB11-1024B		✗			✗			✗
VEB11-0812I			✗			✗	✗	
VEB11-3812I				✗		✗	✗	

ANCHORING ORIENTATION

- * The best orientation: Filters looking down.
- * Acceptable orientation: Filters in horizontal position.
- * Non-acceptable orientation: Filters looking up.

THE BEST ORIENTATION

(Filters looking down)

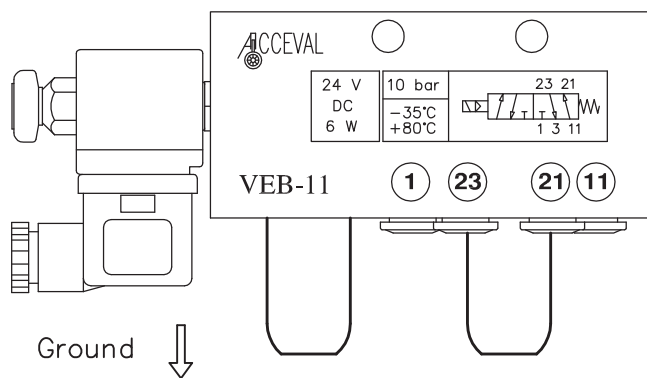

ACCEPTABLE ORIENTATION

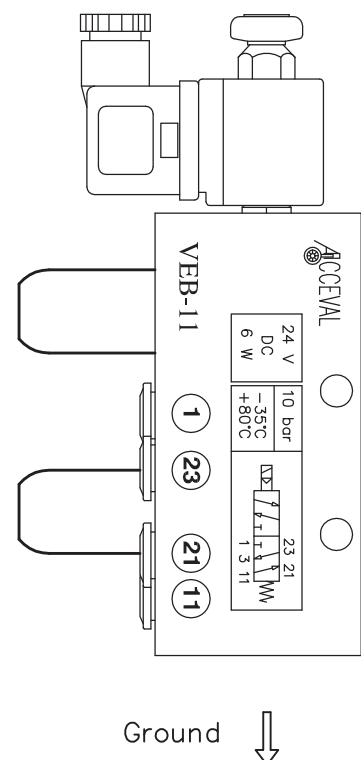

ACCEPTABLE ORIENTATION

