

MANUAL CONTROL OF TWO LIFT AXLES (FIRST AND SECOND)

NOTE: 2nd AXLE LIFTING CONDITIONED TO THE 1st.

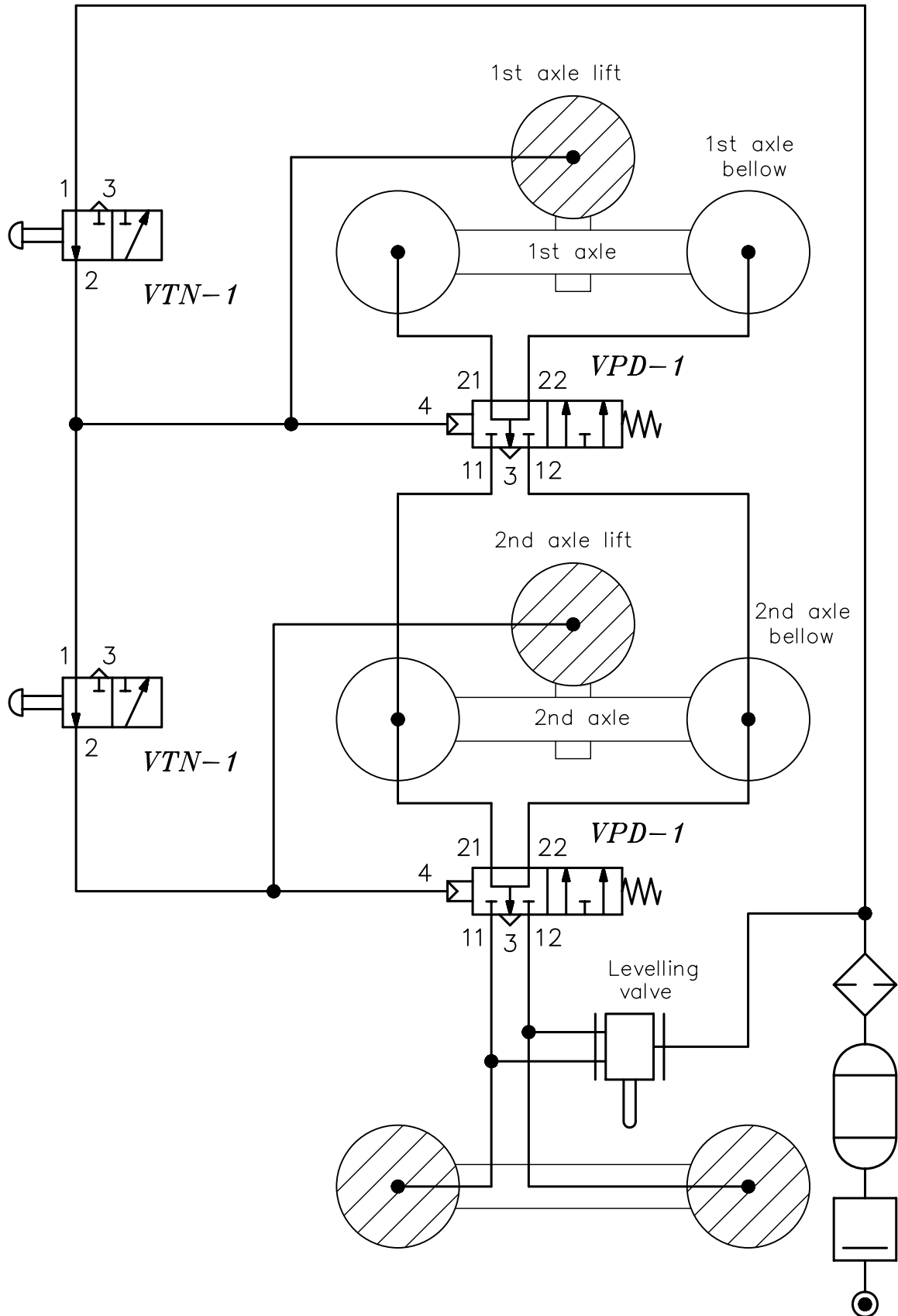

MANUAL CONTROL OF TWO LIFT AXLES (FIRST AND THIRD)

NOTE: 3rd AXLE LIFTING CONDITIONED TO THE 1st.

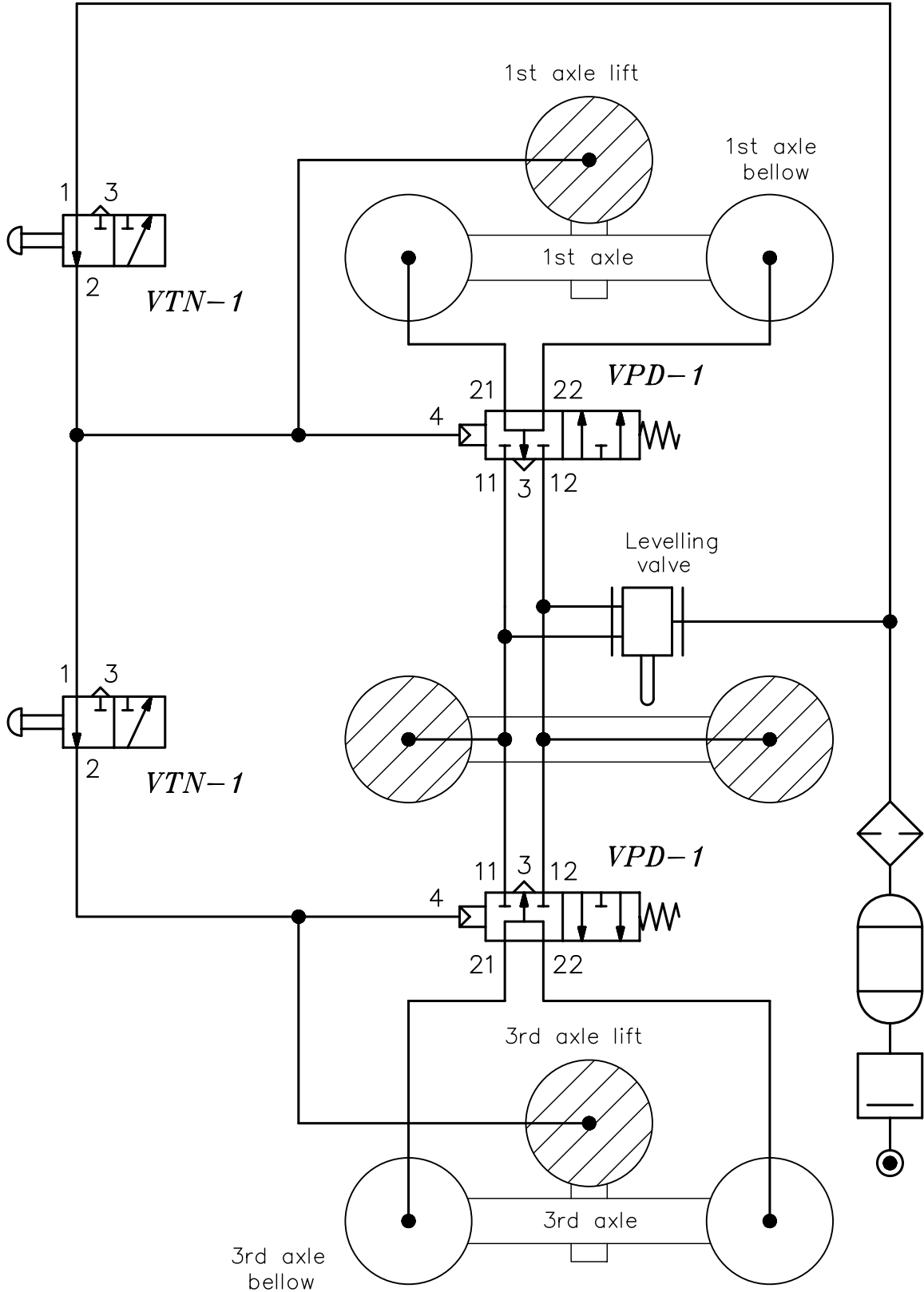

ELECTRIC + MANUAL CONTROL OF TWO LIFT AXLES (FIRST AND SECOND)

NOTE: 2nd AXLE LIFTING CONDITIONED TO THE 1st.

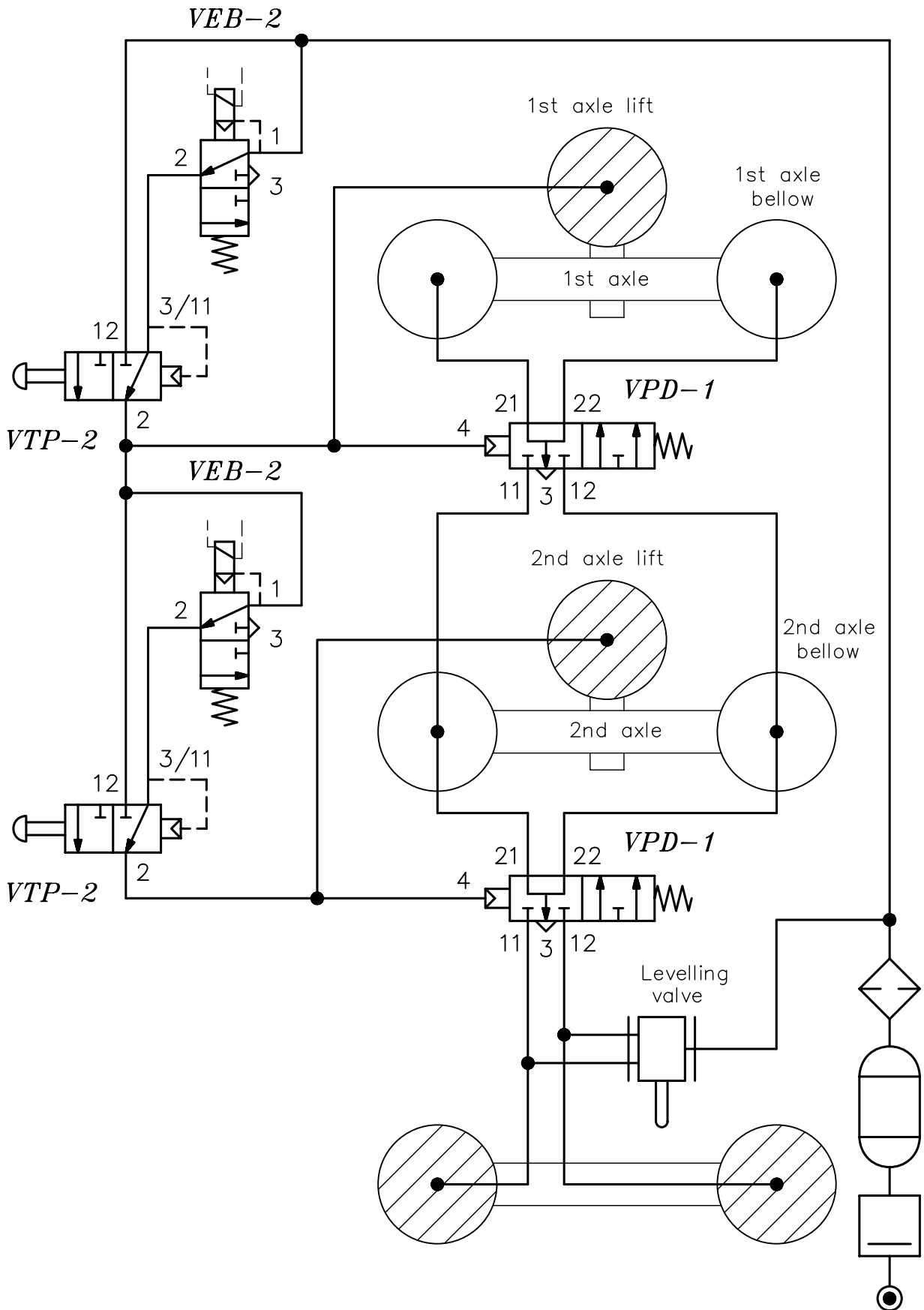

ELECTRIC + MANUAL CONTROL OF TWO LIFT AXLES (FIRST AND THIRD)

NOTE: 3rd AXLE LIFTING CONDITIONED TO THE 1st.

